

9/26/23

Vehicle Parking Committee Update



Committee Members:

Jennifer Jonach	Jim Moran
Fran Chambers	Ceil Roy
Marion Hubbard	Joyce Saunders
Roger Kjar	Ken Siefferman
Cindy Maguire	Terry Weis

Working to keep families together!

Recap:

Concern: BOD received several letters from community members expressing the need for truck parking.

Response: Vehicle Parking Committee formed with mission
“Working to keep families together!”

Concern: The Village of Tequesta does not allow Pick-up Trucks.

Response: **NOT TRUE!!** Ordinance 17-21 permits personal use pick-up trucks.

Concern: Driveways are too narrow.

Response: Driveways in Tequesta Gardens meet Village of Tequesta Code requirements and provide adequate space for trucks to navigate.

Concern: Backing out of spaces, there isn't enough room – might hit AC units.

Response: Driveways provide ample space for pick-up trucks to maneuver.

Village of Tequesta

No Restrictions on Personal Use Pick-up Trucks

- WHEREAS, general state law continues to allow local governments to regulate the stopping, standing, and parking of vehicles within their jurisdictions as provided by Section 316.008, Florida Statutes.
- Village Code for R-1 and R-1A; silent on R-2 and R-3
- **12) The provisions and conditions set forth in this section are not intended to regulate the parking of vehicles only used for personal transportation and not used or intended to be used for commercial purposes.**

Ordinance No. 17-21 | Code of Ordinances | Tequesta, FL
| Municode Library



Tequesta Gardens
Paving & Striping
Approved by
Village of Tequesta

FIELD COPY
REVIEWED FOR
CODE COMPLIANCE

VILLAGE OF TEQUESTA, FLORIDA
BUILDING PERMIT NO. B15-000120
REVIEWED FOR CODE COMPLIANCE
DATE 4/27/15
BY [Signature]
Building Official
THIS REVIEW DOES NOT WAIVE ANY REQUIREMENTS
OF THE VILLAGE OF TEQUESTA BUILDING CODE
FOR THIS STRUCTURE

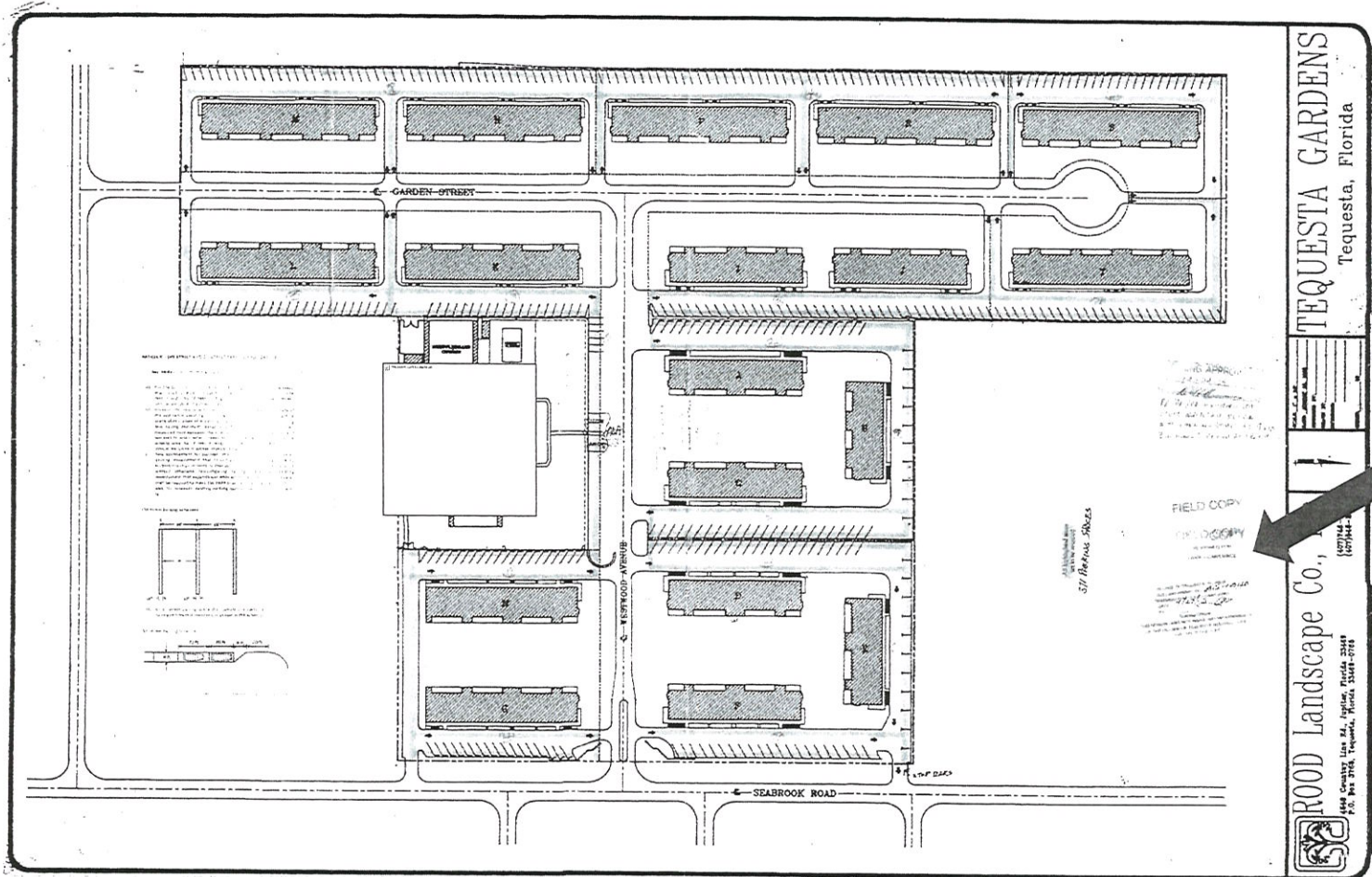

TEQUESTA GARDENS
Tequesta, Florida

DATE	4/27/15
BY	[Signature]
TITLE	FIELD COPY

FIELD COPY
FIELD COPY

WOOD Landscape Co., Inc.
1400 S.W. 11th St., Ft. Lauderdale, FL 33304
P.O. Box 2784, Tequesta, Florida 33469-0278

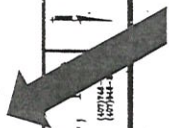

Agenda for Today:



Concerns about
Parking Space Size



Concerns about Noise
– Diesel



Truck Sizes and
General Info about
Trucks



Alternate Solutions for
Vehicles Exceeding
Designated Space



Enforcement



Community
Benchmarks

Top 12 Selling Vehicles In America

As of: July 17, 2023

25 Best-Selling Cars of 2023, So Far - Kelley Blue Book (kbb.com)

1. Ford F-Series



Total Units Sold: 212,516

The F-Series pickup truck continues to be the most popular vehicle in America, with sales up 1.1% from 2022. The F-Series pickup truck is available in 15 different configurations, including the F-150, F-250, F-350, F-450, and F-550. The F-Series pickup truck is also available in a variety of colors, including the new 'Velocity Blue' color.

2. Chevrolet Silverado



Total Units Sold: 140,076

The Chevrolet Silverado pickup truck is the second most popular vehicle in America, with sales up 1.1% from 2022. The Silverado pickup truck is available in 15 different configurations, including the Silverado 1500, Silverado 2500, and Silverado 3500. The Silverado pickup truck is also available in a variety of colors, including the new 'Silverado Metallic' color.

3. Ram Pickup



Total Units Sold: 117,699

The Ram pickup truck is the third most popular vehicle in America, with sales up 1.1% from 2022. The Ram pickup truck is available in 15 different configurations, including the Ram 1500, Ram 2500, and Ram 3500. The Ram pickup truck is also available in a variety of colors, including the new 'Flame Red' color.

4. Tesla Model Y



Total Units Sold: 105,500

The Tesla Model Y electric SUV is the fourth most popular vehicle in America, with sales up 1.1% from 2022. The Tesla Model Y is available in 15 different configurations, including the Model Y Long Range and Model Y Performance. The Tesla Model Y is also available in a variety of colors, including the new 'White' color.

5. Toyota RAV4



Total Units Sold: 102,313

The Toyota RAV4 SUV is the fifth most popular vehicle in America, with sales up 1.1% from 2022. The RAV4 SUV is available in 15 different configurations, including the RAV4 Hybrid and RAV4 Hybrid Limited. The RAV4 SUV is also available in a variety of colors, including the new 'Magnetic Gray' color.

6. Honda CR-V



Total Units Sold: 96,456

The Honda CR-V SUV is the sixth most popular vehicle in America, with sales up 1.1% from 2022. The CR-V SUV is available in 15 different configurations, including the CR-V Hybrid and CR-V Hybrid Sport. The CR-V SUV is also available in a variety of colors, including the new 'Canyon Gray' color.

7. Toyota Camry



Total Units Sold: 84,705

The Toyota Camry sedan is the seventh most popular vehicle in America, with sales up 1.1% from 2022. The Camry sedan is available in 15 different configurations, including the Camry Hybrid and Camry Hybrid Limited. The Camry sedan is also available in a variety of colors, including the new 'Magnetic Gray' color.

8. GMC Sierra



Total Units Sold: 75,810

The GMC Sierra pickup truck is the eighth most popular vehicle in America, with sales up 1.1% from 2022. The Sierra pickup truck is available in 15 different configurations, including the Sierra 1500, Sierra 2500, and Sierra 3500. The Sierra pickup truck is also available in a variety of colors, including the new 'Dark Denim' color.

9. Nissan Rogue



Total Units Sold: 71,246

The Nissan Rogue SUV is the ninth most popular vehicle in America, with sales up 1.1% from 2022. The Rogue SUV is available in 15 different configurations, including the Rogue Hybrid and Rogue Hybrid Limited. The Rogue SUV is also available in a variety of colors, including the new 'Brilliant Silver' color.

10. Jeep Grand Cherokee



Total Units Sold: 70,454

The Jeep Grand Cherokee SUV is the tenth most popular vehicle in America, with sales up 1.1% from 2022. The Grand Cherokee SUV is available in 15 different configurations, including the Grand Cherokee L and Grand Cherokee L Limited. The Grand Cherokee SUV is also available in a variety of colors, including the new 'Bright Silver' color.

11. Toyota Tacoma



Total Units Sold: 63,262

The Toyota Tacoma pickup truck is the eleventh most popular vehicle in America, with sales up 1.1% from 2022. The Tacoma pickup truck is available in 15 different configurations, including the Tacoma SR5 and Tacoma SR5 Limited. The Tacoma pickup truck is also available in a variety of colors, including the new 'Magnetic Gray' color.

12. Tesla Model 3



Total Units Sold: 58,500

The Tesla Model 3 electric sedan is the twelfth most popular vehicle in America, with sales up 1.1% from 2022. The Model 3 is available in 15 different configurations, including the Model 3 Long Range and Model 3 Performance. The Model 3 is also available in a variety of colors, including the new 'White' color.

Highlights:

- ❖ The Top 3 vehicles sold in America as of July 2023 are all trucks
- ❖ 5 of the top 12 vehicles sold so far in 2023 are trucks
- ❖ The Ford F-150 has been the #1 selling vehicle in America for 46 years!
 - ❖ Ford F-150 is Ford's #1 selling vehicle in the world
 - ❖ Ford will stop producing some sedans because demand has dropped so much
- ❖ 4 of the top 12 vehicles are SUVs – *which weren't permitted to park in Tequesta Gardens until 2004 when an Amendment was made to the Declarations of Condominium for TG*
- ❖ 2 of the top 12 vehicles are electric vehicles
- ❖ 1 of the top 12 vehicles is a standard gasoline powered sedan

Resident Concern: Concerns About Size of Parking Spaces

- Trucks don't fit in spaces
- Trucks stick out too far and block people from backing out



Will trucks fit in Tequesta Gardens?

Village of Tequesta Sec. 78-691. - Minimum Standards

(a) For the purpose of this chapter, an existing off-street parking space shall consist of a parking space having minimum dimensions of nine feet in width by 18 feet in length for the parking of each motor vehicle, excluding access drives or aisles thereto, sidewalks, and interior pedestrian walkways.

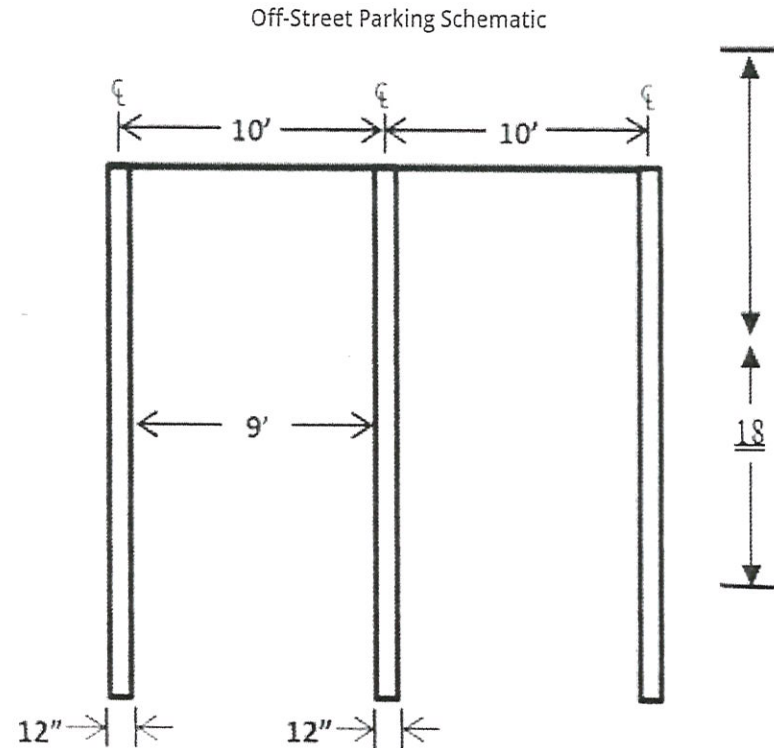

Minimum required space length in Tequesta is 216".

Village of Tequesta Sec. 78-691. - Minimum Standards

(d) Overhang areas. Vehicle parking areas designed to permit vehicles to overhang curbing may not be counted as part of a sidewalk or interior walkway. Such overhang shall be in addition to the required dimensions of sidewalks and interior walkways.

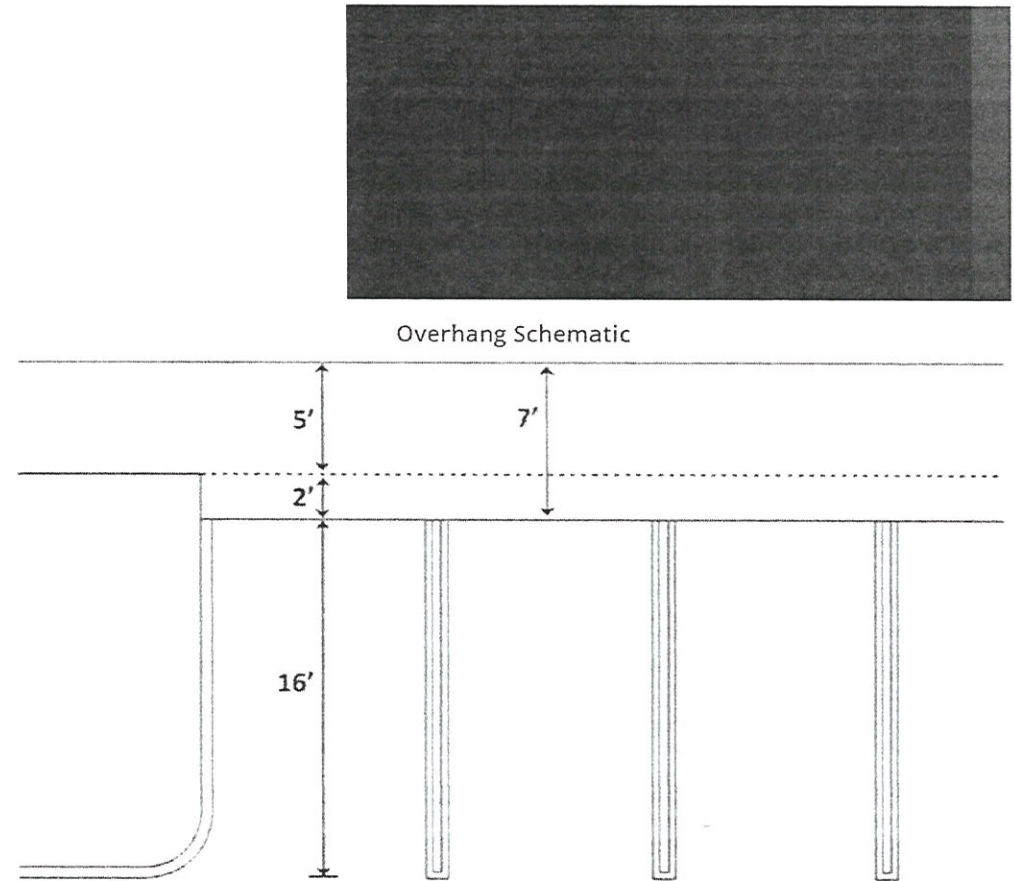

Utilizing overhang area the total can be 240" or greater.

Frequently Visited Areas – Town of Jupiter:

Standard Parking
Slightly Smaller
than Tequesta but
overhang exists in
many places

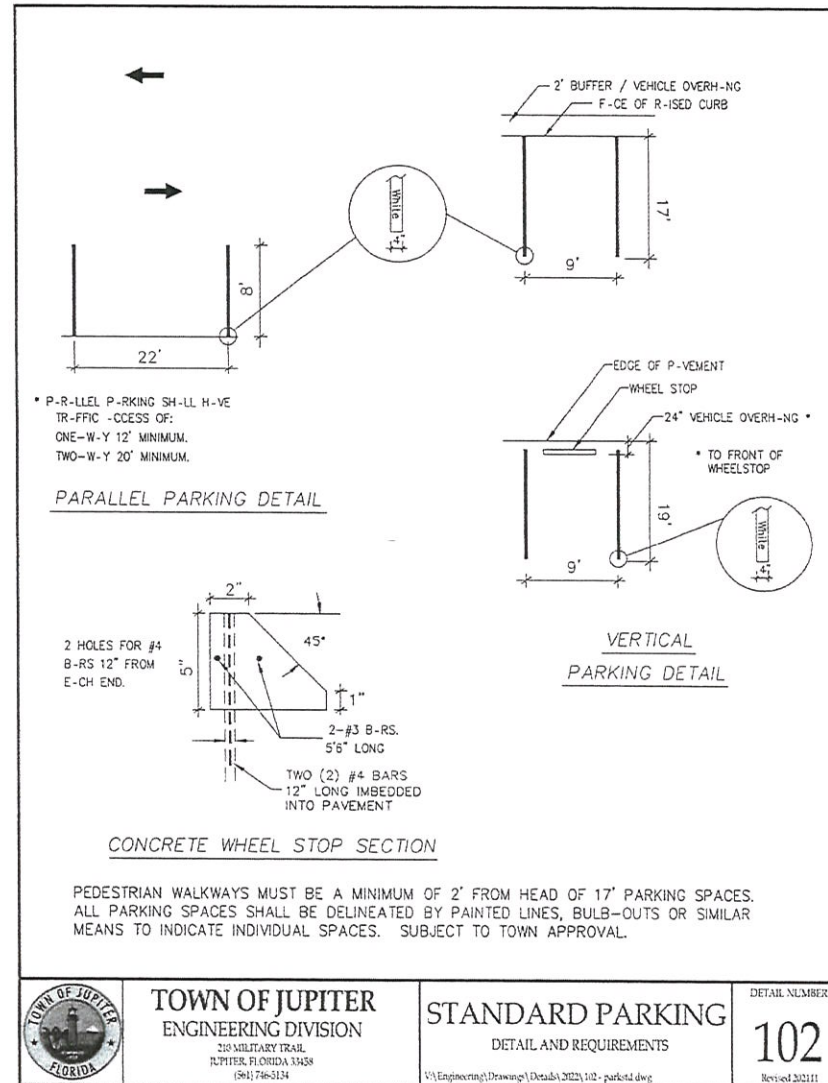

Top 3 Truck Sizes:

Ford F-150

209 – 231”



Chevrolet Silverado

205 – 235”



Chrysler Ram

229 – 232”



Just To Make Sure

- Members of the team went out into the community and measured various places.
- They confirmed that the measurements meet the code requirements.
- There are many areas of the community that provide even more space than what is required.
- The paving schematic approved by the Village demonstrates that Tequesta Gardens is compliant with the Village Code.

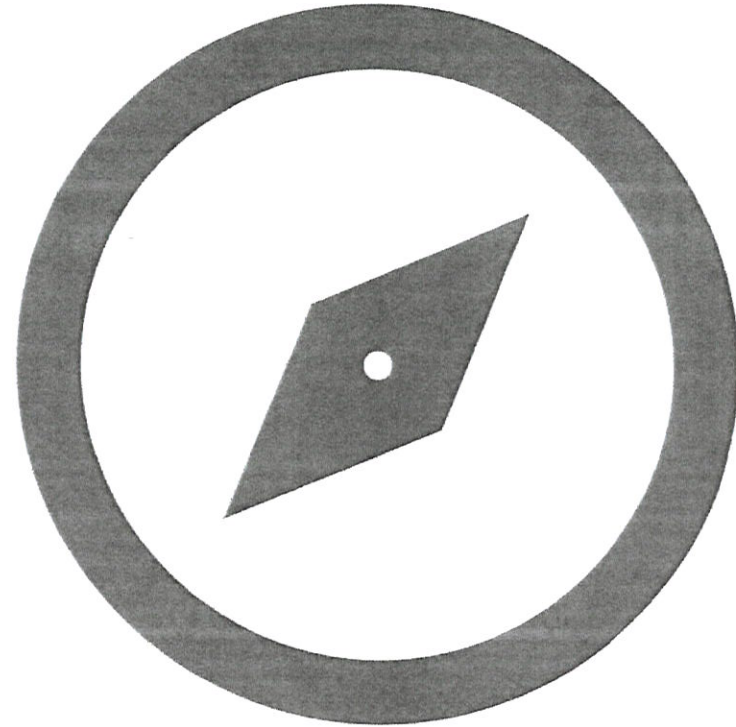

SUVs in Tequesta Gardens:

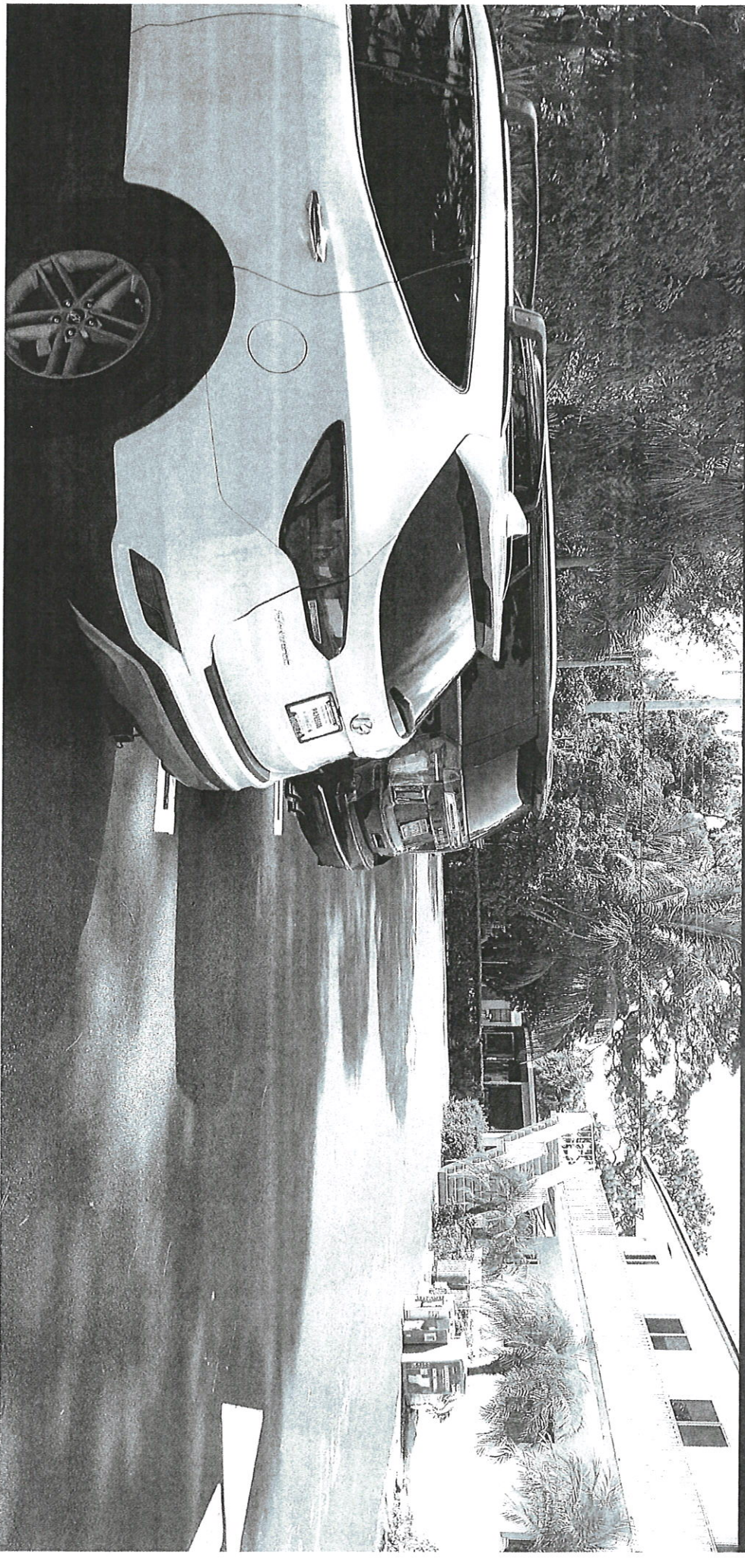

Another Perspective in Tequesta Gardens:

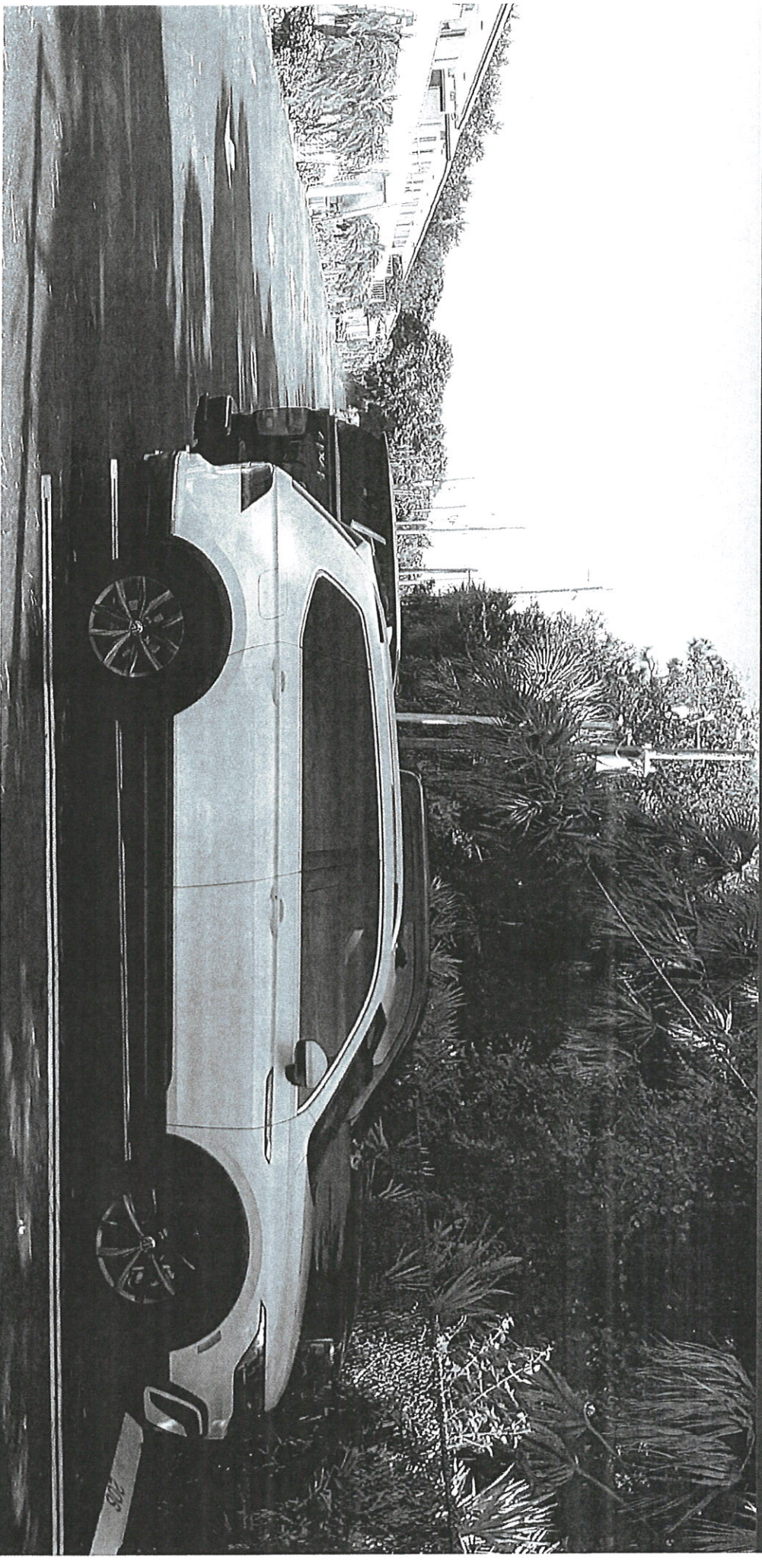

Cars, SUV's and Trucks in Tequesta Gardens:

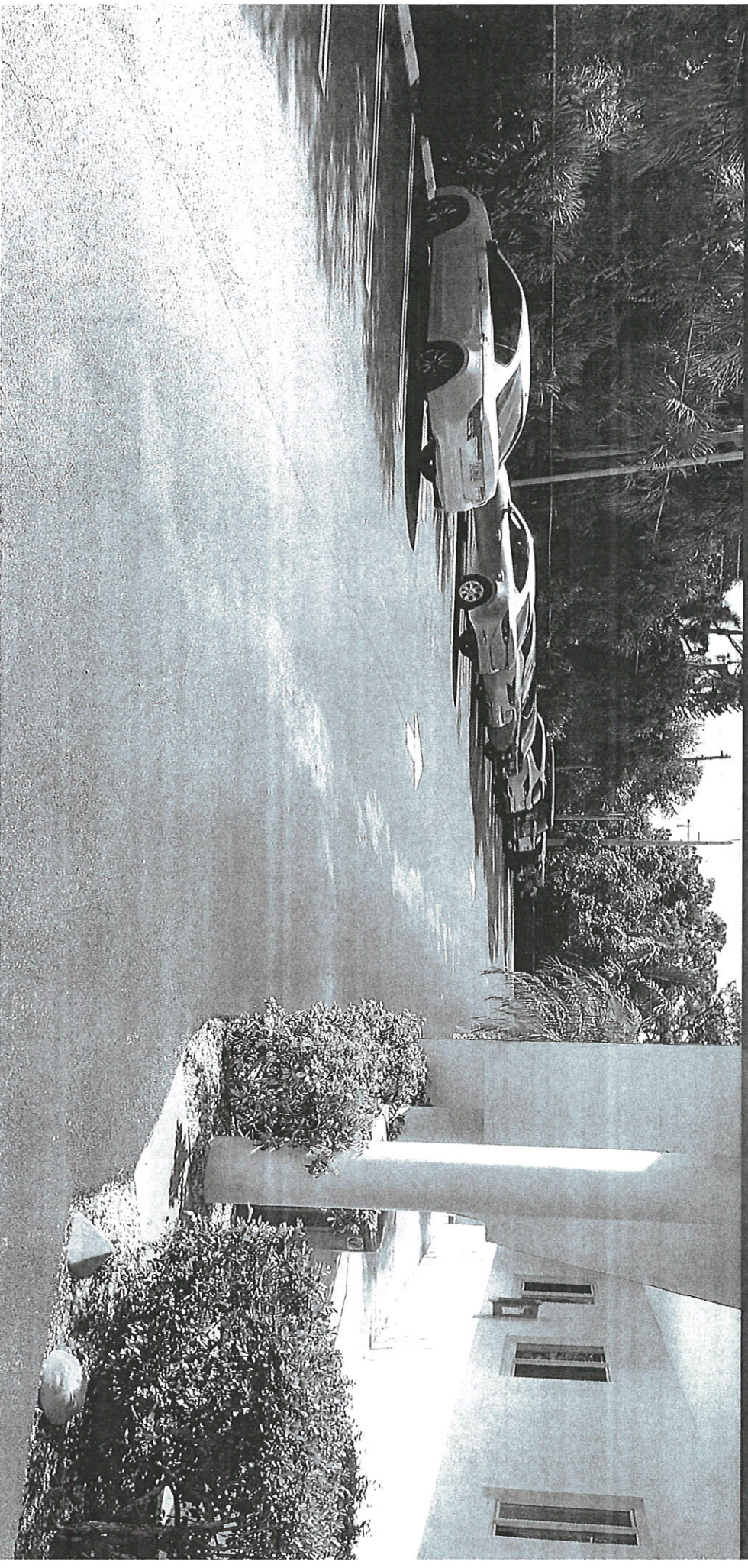



Conclusions:

WILL TRUCKS FIT????

The answer is..... It Depends....

- Trucks are very popular passenger vehicles
- Trucks come in many different sizes
- The overhang on different vehicles also varies
- To propose a recommendation based on dimensions would not make sense
- Despite Tequesta and Jupiter having different size parking spaces, trucks are parked everywhere

Resident Concern: Noise

- Diesel trucks make too much noise





Concerns about Noise

- The committee does not recommend excluding diesel trucks from parking on the property.
- The committee will not recommend a noise restriction that is specific to trucks.
- Any restriction on noise should be more encompassing and include all vehicles.
- Noise is a very difficult thing to regulate.
- We believe this concern should be addressed by existing Nuisance language in our Documents.

DRAFT Recommendations:

- Approve the parking of resident and guest owned pick-up trucks in Tequesta Gardens.
- Trucks must be used solely for personal transportation. No commercial vehicles or other non-personal use.
- Equipped with original automobile manufacturer's factory design.

Residents:

- If it fits in your assigned space, you can park there.
- All vehicles, including trucks, must fit in the space. If they are off by a few inches, we can look at moving the tire stops or other accommodations.
- Alternate space assignments will be an option.
- Either the Truck owner or the neighboring space assignment holder can request a change.
- Residents cannot have more than one assigned space. If assigned an alternate space, the original assigned space will be designated a Visitor spot.
- If an alternate space is not available, street parking will be required.

Guests:

- Must fit in Visitor space.
- Street parking is an alternative.

DRAFT Recommendations (Cont.):

- Several spaces by 5 & 7 Westwood offer wider aisles and may be assigned by the office or used on a temporary basis by Visitors.
- No tags or special registration with the office required for either residents or guests.
- Must be kept neat and tidy – or covered.
- Same requirements would apply to SUVs.

Restrictions:

- No Commercial vehicles
- Single axle trucks only
- Dual wheel rear tires prohibited
- No advertising or commercial markings
- No after-market lift kits
- No ladder racks

Resident Concern: Enforcement

- How will we enforce the truck restrictions?



Enforcement

- Simple recommendation that does not require any special enforcement.
- Trucks would be treated like any other vehicle.

Resident Concern: Property Value & Aesthetics

- Will property values will go down if we allow trucks?
- Trucks are ugly and will make the complex look cheap.



Benchmarking Other Communities

Tequesta & Jupiter



Abacoa – Truck parking on street in driveways allowed

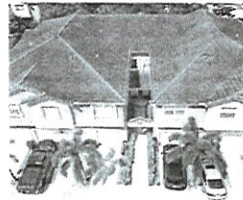

Tequesta Trace – Truck parking in driveways allowed



Jupiter Bay – Trucks allowed

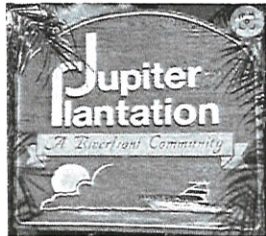

Jupiter Plantation – Person pick-up trucks allowed



Blair House – Person pick-up trucks allowed



Tequesta Hills – Recently changed rules to allow Trucks



Bella Villaggio – Pick-up trucks allowed in driveways or garage

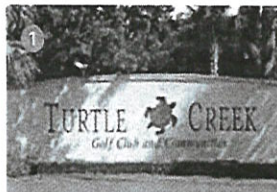

Turtle Creek Village – Pick-up trucks allowed



Tequesta Pines – Trucks allowed

Property Values & Aesthetics Conclusions:

- Village of Tequesta has embraced personal use truck parking in residential areas
 - Pick-up trucks do not have a negative effect on the residential character of the Village.
 - Pick-up trucks do not have a negative effect on the welfare of the community.
 - Pick-up trucks do not have a negative effect on the aesthetic appeal of the Village.
- Nearby private homes and condos allow truck parking
- Property values in the surrounding area have skyrocketed in recent years
- Properties that allow truck parking have not been negatively affected
- Newly constructed properties realize trucks are a popular vehicle choice and are not restricting them
- If selling your property, having more buyers able to purchase your unit is a benefit. Did you know that 20% of the US population drives a pick-up truck?

Remember: Your neighbors and friends have asked for your support to make this change for our community.

Other Resident Concerns To Be Addressed

Safety ✓

Property
Value ✓

Aesthetics ✓

Noise ✓

Enforcement ✓

Next Steps:

- Work with our attorney to prepare documents for final Board and Community vote
- Schedule Coffee And... and other Community Engagement sessions to get additional input and to answer questions for owners
- Finalize schedule for Board and Community Vote

Working to keep families together!



Committee Members:

Jennifer Jonach

Fran Chambers

Marion Hubbard

Roger Kjar

Cindy Maguire

Jim Moran

Ceil Roy

Joyce Saunders

Ken Siefferman

Terry Weis

THANK YOU!!!